

NETZSCH

Proven Excellence. ■

Bombas & Sistemas

NETZSCH

Proven Excellence.

Tecnologia IoT Plug and Play para o monitoramento de máquinas industriais

22º Seminário Brasileiro Agroindustrial – A Usina Digital



50.000

Bombas produzidas por ano

90

Número de países onde atuamos

60

Anos de experiência e mais



1ª Bomba NETZSCH (1878) para combate a incêndio,
bombeiros voluntários Weissenbach.

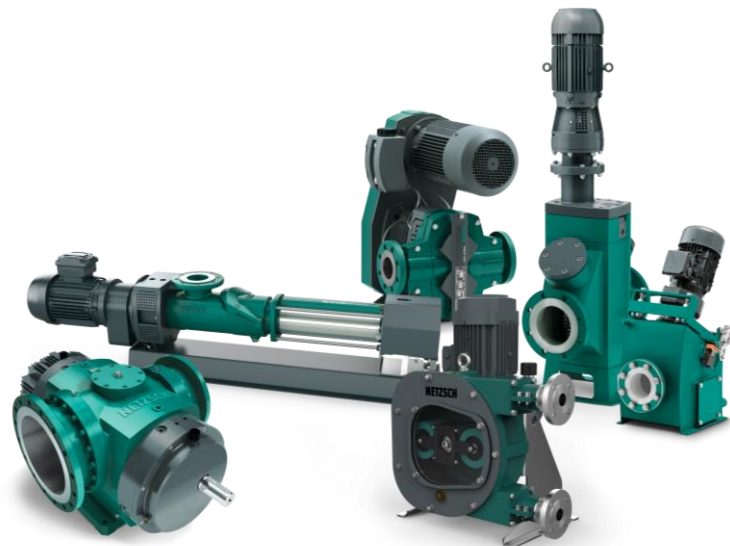

Linha de produtos atual
NETZSCH Bombas & Sistemas

➤ Inovações Core Business

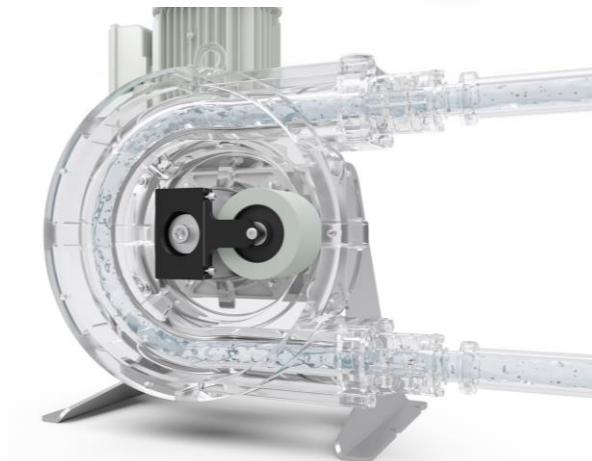
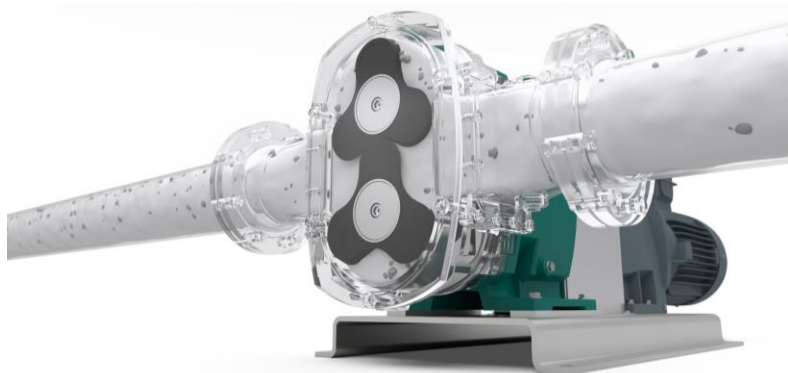
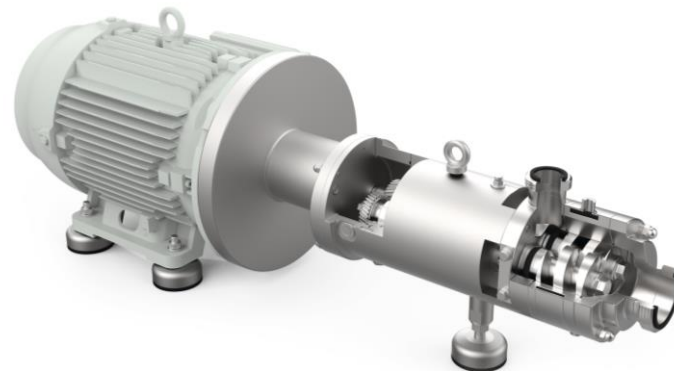
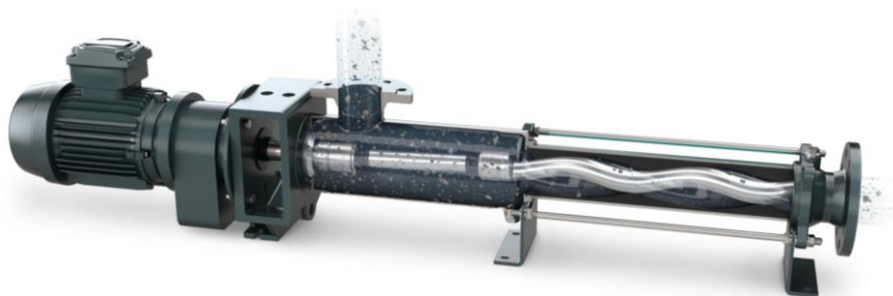

➤ Inovações Adjacentes



LabV - connecting everything
devices, people and processes connected to simplify,
secure and make use of your data

www.labv.io



SISTEMAS DE CONTROLE

NETZSCH NOTIFY

Monitoramento de Máquinas em Tempo Real



sens X PERT

**Innovative
sensors creating
intelligent molds**

Como são realizadas as manutenções atualmente?

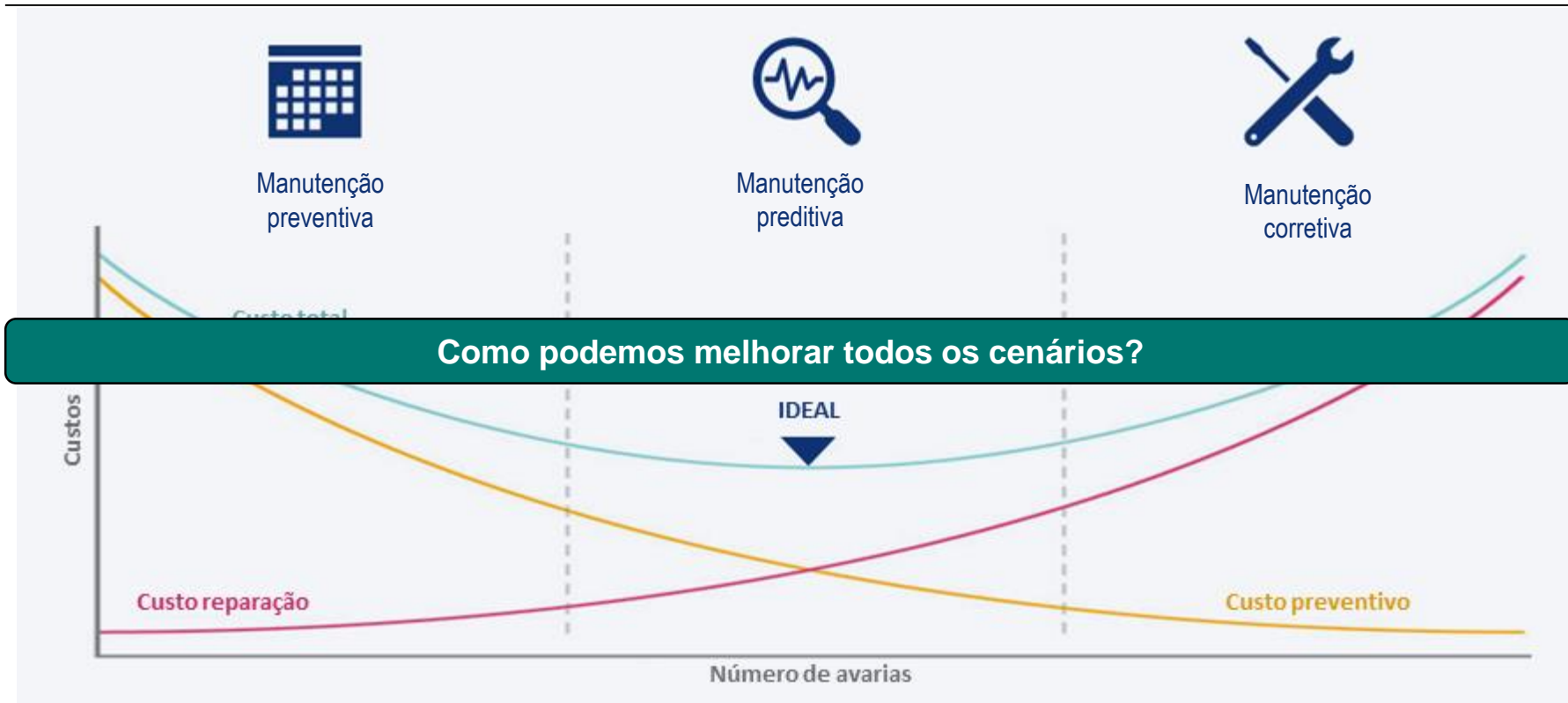

KAIZEN INSTITUTE. **Switching From Reactive to Predictive Maintenance.** 1 mar. 2023. Gráfico. Disponível em: <https://au.kaizen.com/products/reactive-predictive-maintenance>. Acesso em: 20 out. 2023.

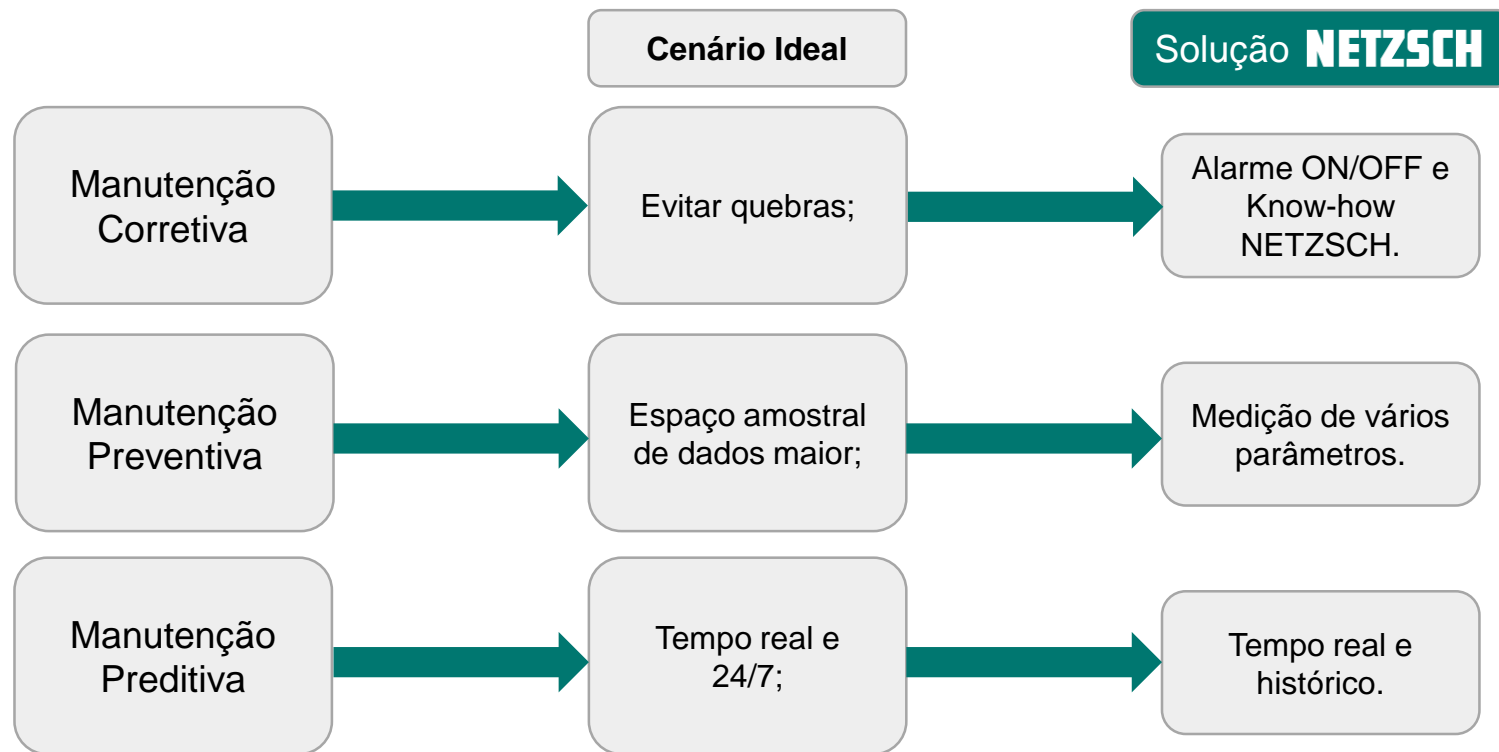



NEXUS.PRO para bombas

Temperatura, Pressão sucção
Pressão descarga, Vibração,
Dados de Motor Elétrico ...

Alarmeria,
Controle,
Telemetrias,

Cálculo da eficiência
volumétrica,
Proteção contra trabalho a seco

Variáveis

Recursos

Aplicações

NEXUS.ALL para equipamentos ...

Qualquer

Alarmeria,
Controle,
Telemetrias,

+ know-how NETZSCH

Utilização Fixa



- Equipamentos cruciais do processo;
- Histórico;



Utilização Portátil



- Equipamentos com problemas pontuais;
- Flexibilidade;



Monitoramento Redutor Moenda
Portátil



Monitoramento Bomba Centrífuga
Portátil



Monitoramento Bomba de Fusos
Fixo

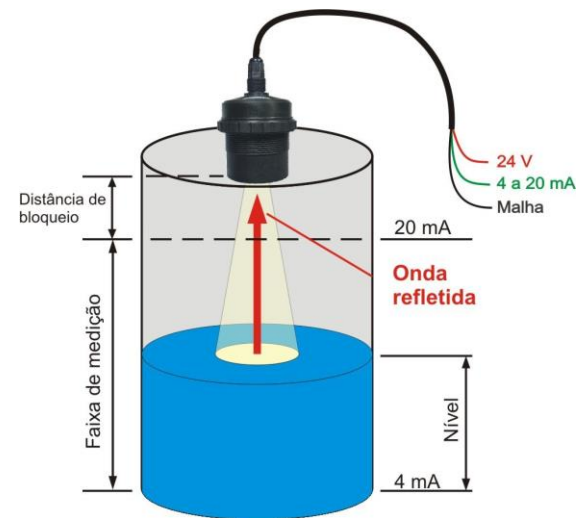

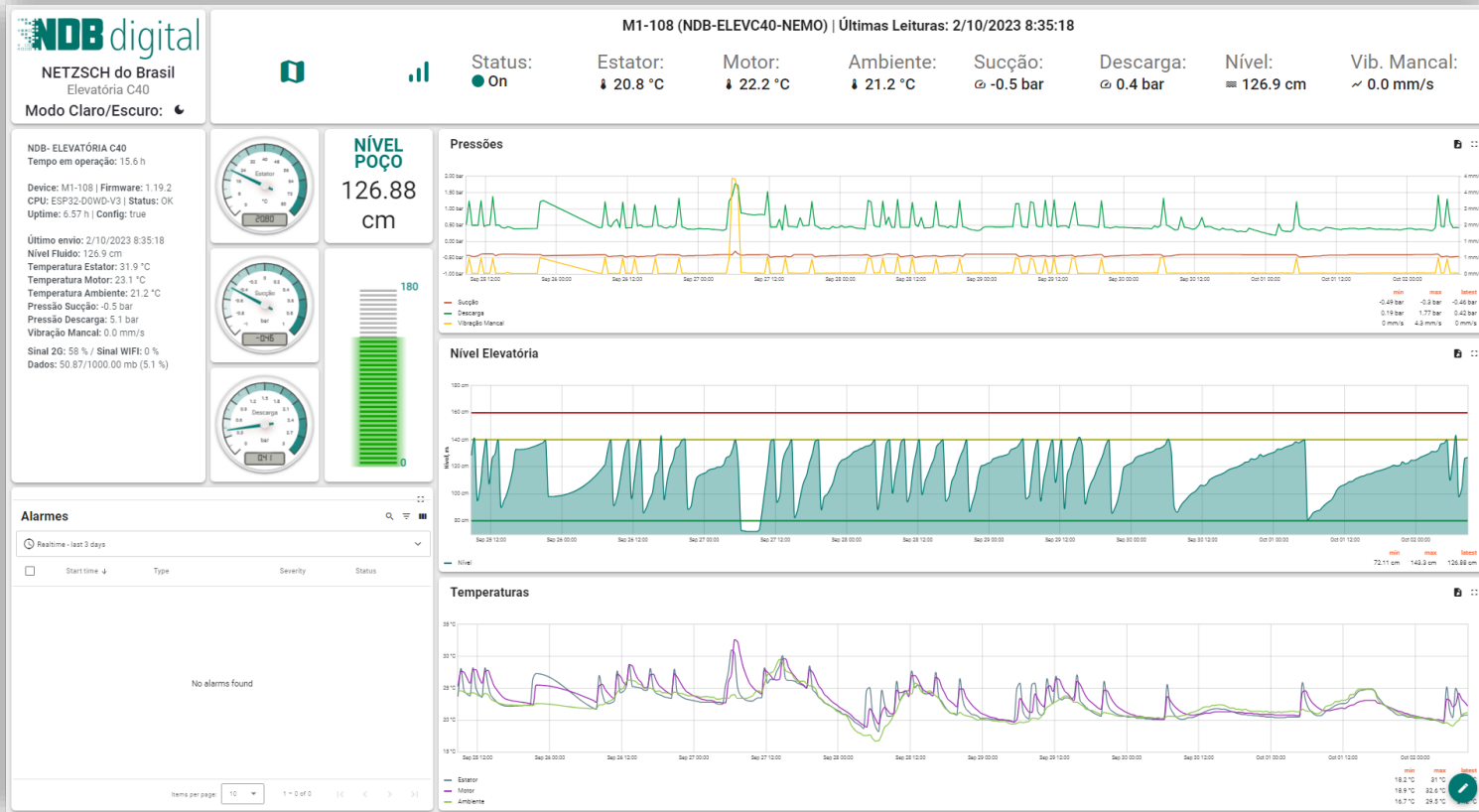



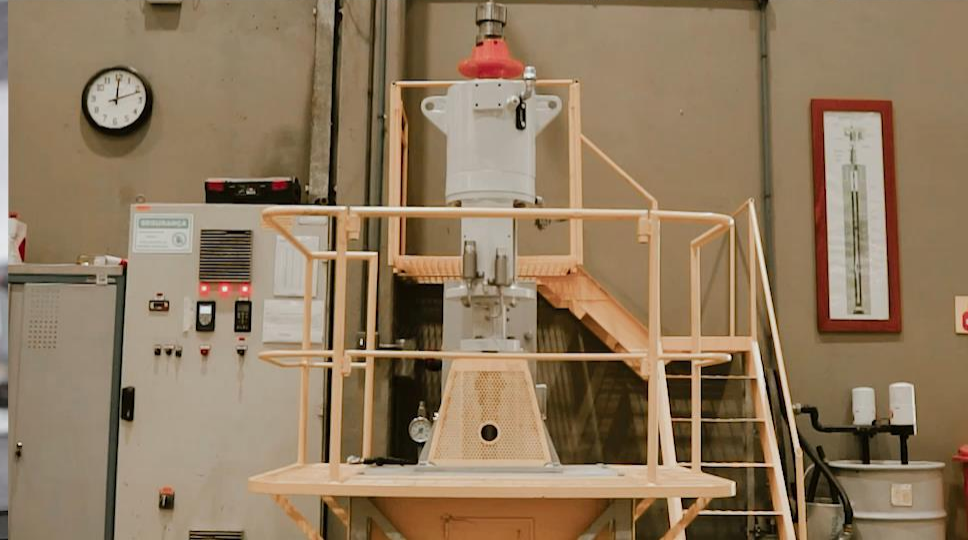



NETZSCH

Proven Excellence.

Você pode confiar na NETZSCH.